

EM530



Energy analyzer for three-phase and two-phase systems



Description

EM530 is an energy analyser connected through 5 A or 333 mV current transformers, for two- and three-phase systems up to 415 V L-L. In addition to a digital input, the unit can be equipped, according to the model, with a static output (pulse or alarm), a Modbus RTU communication port or an M-Bus communication port.

Benefits

- **Enhanced readability.** The backlit display ensures perfect visibility even in low light. The different size of the digits preceding and following the dot makes the displayed values easier to read, while the essential style of the units of measure allows you to readily understand the available variables.
- **Easy browsing.** Page configuration and browsing are very intuitive, thanks to the user interface with 3 mechanical keys. The slideshow function automatically displays the desired measurements in sequence, without having to use the keyboard; the page filter allows you to hide the unnecessary information.
- **Quick configuration.** The configuration wizard which runs when the system is started up for the first time allows you to commission the unit without errors in a matter of seconds. The UCS configuration software is available for download free of charge.
- **Accurate measuring.** EM530 complies with the precision international standard EN IEC 62053-21, and with the performance requirements (power and active energy) set out by EN IEC 61557-12.
- **Fiscal metrology.** The sliding terminal caps (patent application pending in EU, US, CA, AU), can be sealed to prevent any tampering with the connections, allowing the unit, thanks to the MID certification, to perform measurements for fiscal purposes and a reinforced protection toward the power terminals.
- **Flexible installation.** It can be installed in two-phase, three-phase with neutral, three-phase without neutral, and wild-leg three-phase low-voltage systems, with operating temperature up to 70 °C / 158 °F .
- **Powerful integration.** In combination with UWP (an energy monitoring and control gateway manufactured by Carlo Gavazzi), it allows you to build a scalable and flexible system to monitor the energy efficiency of buildings and equipment.

Applications

EM530 can be installed in any low-voltage switchboard, to monitor the energy consumption, the main electrical variables and the harmonic distortion. Compatible with any current transformer with 5 A / 333 mV secondary current, it can be installed in systems with rated current up to 10 kA, even in retrofit applications if used with openable transformers like CTA, CTD S or CTV.

If used to monitor a single machine, it provides all the main electrical variables to identify any possible malfunction in its early stage and can correlate the energy consumption with the hours of operation, to plan maintenance and prevent failures. The partial meter reset function, easily implementable by means of a digital input, allows you to monitor each individual machine cycle.

The MID-certified version can be used for fiscal metrology and can be installed in residential or commercial buildings to split the costs among the different units, or as a component of machines or equipment requiring measurement certification.

Dedicated versions able to operate up to 70°C / 158°F (PFx70 models), are the best solution for installation in electric vehicles chargers placed outdoor and exposed to high temperature or direct solar radiation. The MV5 version is particularly suitable for residential EV charging or load management.

Thanks to the measurement refresh time and to the high resolution of the variables available through a Modbus RTU communication module, it can also be used as data source for control actions, such as avoiding feeding energy into the electricity grid in a photovoltaic joint installation with energy storage.

Main functions

- Measure active, reactive and apparent energy
- Measure the main electrical variables
- Measure the load run hours and of the analyser
- Measure the total harmonic distortion (THD) of current and voltages
- Transmit data to other systems through Modbus RTU or M-Bus
- Manage a digital output for pulses or alarm transmission
- Visualize the measured variables on the display

Main features

- System and phase variables (V L-L, V L-N, A, W/var, VA, PF, Hz)
- Compatible with any current transformer with 5 A or 333 mV current sensors
- Displaying of the consumed active energy with a resolution of 0.001 kWh
- The frequency value is available via Modbus, with a resolution of 0.001 Hz
- Average value calculation (dmd) for current and power (kW/kVA)
- Streamlined user interface featuring 3 mechanical buttons
- Modbus RTU RS485 (data refresh every 100 ms)
- Continuous sampling of each voltage and current
- Backlit LCD display
- MID certified version
- MID-certified meter resolution 0.001 kWh
- cULus approved (UL 61010)
- Compliance with the performance requirements set out by EN IEC 61557-12 (power and active energy)
- Operating temperature up to 70 °C / 158 °F temperature (PFx70 models)

UCS software

- Free download from Carlo Gavazzi website
- Configuration through RS485 from PC or through UWP via LAN or the web (UWP Secure Bridge function)
- Setups can be saved offline for serial programming with a single command
- Real time data view for testing and diagnostics
- Notification of possible wiring errors and display of the corrective steps, reassignment of the correct association of the phases or the direction of the currents via software control.

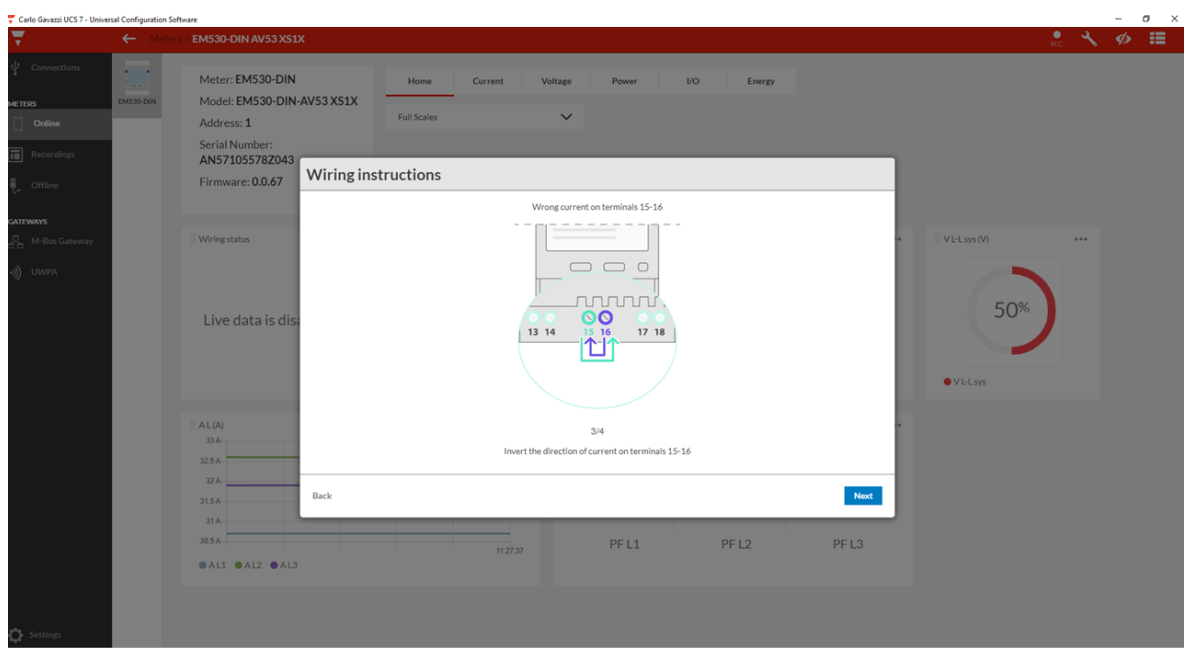
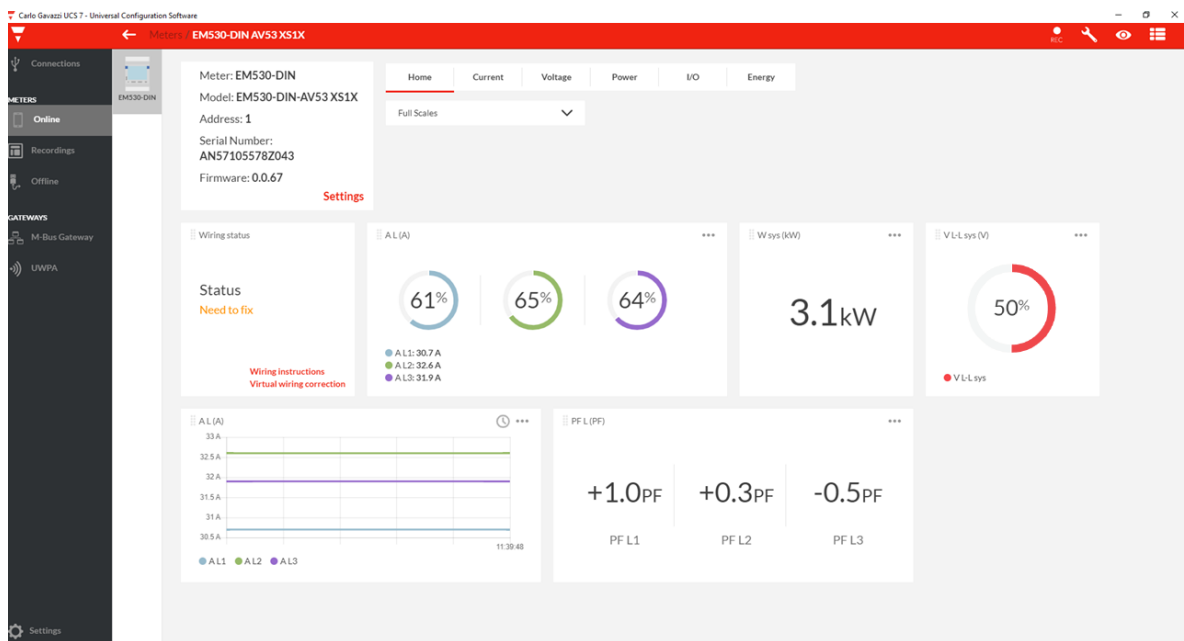

Structure

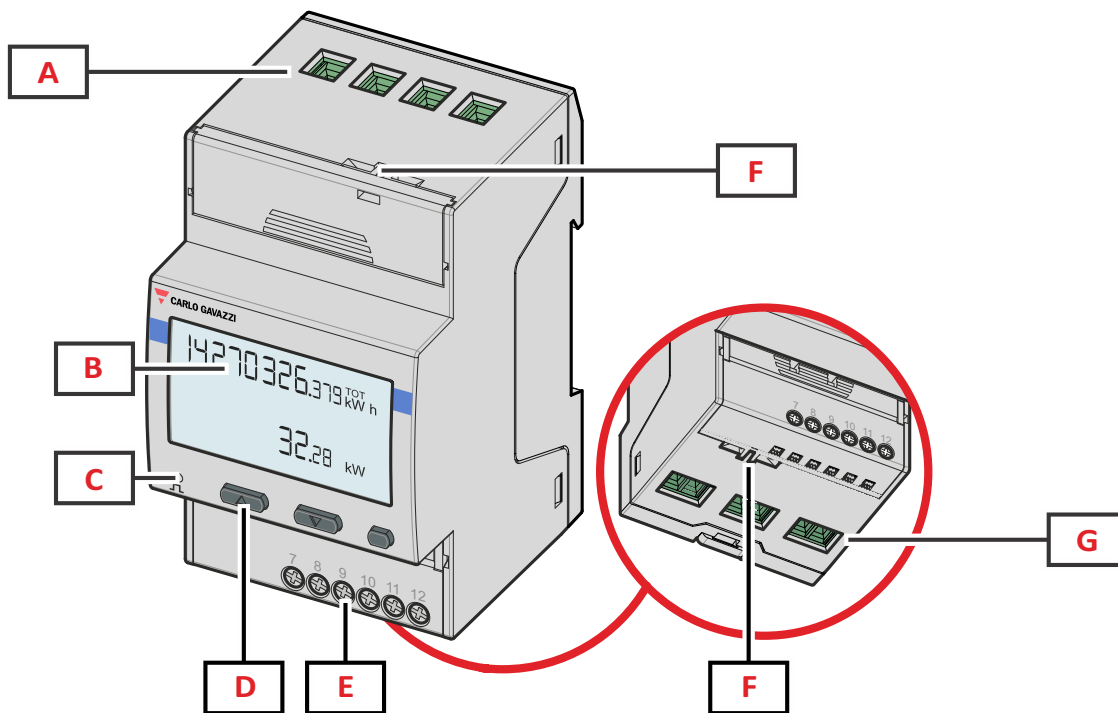

Fig. 1 Front

Area	Description
A	Voltage inputs
B	Display
C	LED
D	Browsing and configuration buttons
E	Digital input, digital output and communication connections
F	MID seal housings
G	Current inputs

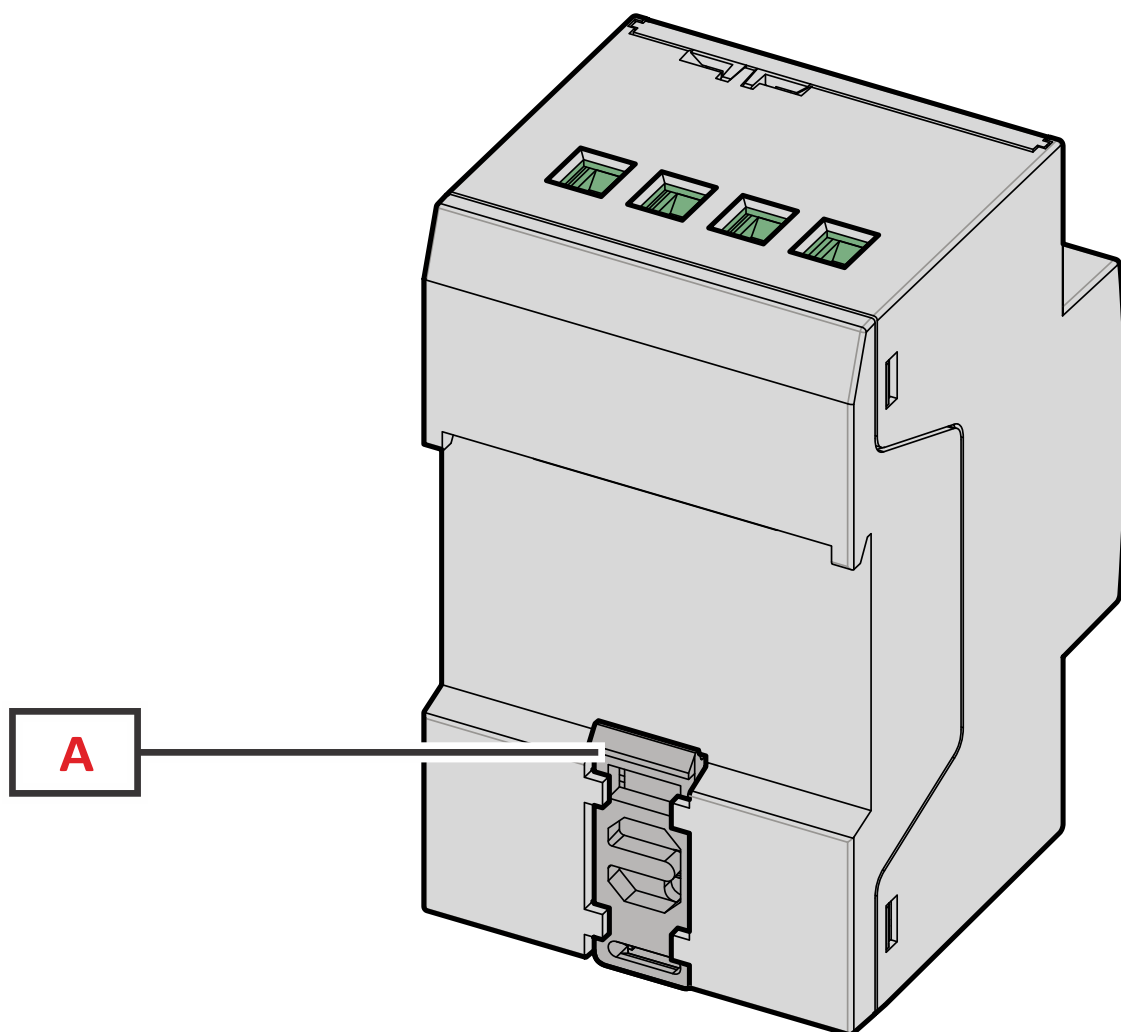

Fig. 2 Back

Area	Description
A	DIN rail mounting bracket

Features

General

Material	Housing: PBT Transparent cover: polycarbonate
Protection degree	Front: IP40 Terminals: IP20
Terminals	Voltage inputs: 0.2 to 2.5 mm ² / 13 to 24 AWG, 0.45 Nm / 3.98 lbin max . Current inputs: 0.2 to 2.5 mm ² / 13 to 24 AWG, 0.45 Nm / 3.98 lbin max . Inputs, outputs and communication: 0.2 to 1.5 mm ² / 16 to 24 AWG, 0.4 Nm / 3.54 lbin max .
Overvoltage category	Cat. III
Pollution degree	2
Mounting	DIN rail
Weight	280 g / 0.62 lb (packaging included)
Dimensions	3-DIN modules

	M1	O1	S1	MV5
MTBF (Mean time between failures)*	94 years	96 years	98 years	95 years

***Note:** MTBF is calculated according to Siemens Norm SN29500, considering a mean ambient temperature of 50 °C / 122 °F. The value of MTBF (Mean Time Between Failures) is the sum of MTTF and MTTR (Mean Time To Repair). For all the products, the MTTR is negligible with respect to the MTTF, so that we can consider MTBF = MTTF.

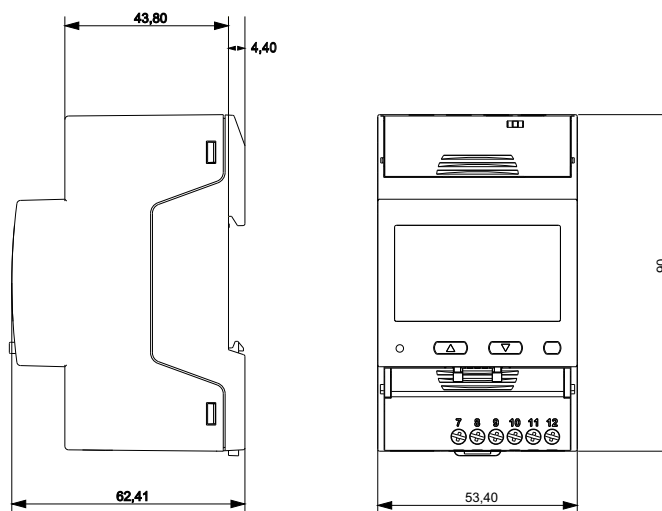

Fig. 3

Environmental specifications

Operating temperature	From -25 to +55 °C / from -13 to +131 °F (X, PFx models) From -25 to +70 °C / from -13 to +158 °F (PFx70 models)
Storage temperature	From -30 to +70 °C / from -22 to 158 °F

Note: R.H. < 90 % non-condensing @ 40 °C / 104 °F.

Input and output insulation

AV5

Type	CT input	Voltage input	Digital input	Digital output	Serial port
CT input	-	Basic	Double/Reinforced	Double/Reinforced	Double/Reinforced
Voltage input	Basic	-	Double/Reinforced	Double/Reinforced	Double/Reinforced
Digital input	Double/Reinforced	Double/Reinforced	-	none	none
Digital output	Double/Reinforced	Double/Reinforced	none	-	-
Serial port	Double/Reinforced	Double/Reinforced	none	-	-



According to: EN 61010-1, EN IEC 62052-31 (MID). Overvoltage category III. Pollution degree 2.

MV5

Type	CT input	Voltage input	RS485 serial port	Digital input
CT input	-	Basic	Double/Reinforced	Double/Reinforced
Voltage input	Basic	-	Double/Reinforced	Double/Reinforced
RS485 serial port	Double/Reinforced	Double/Reinforced	-	Double/Reinforced
Digital input	Double/Reinforced	Double/Reinforced	Double/Reinforced	-

According to: EN 61010-1. Overvoltage category III. Pollution degree 2.

Compatibility and conformity

Directives	2014/32/EU (MID) 2014/35/EU (LVT - Low Voltage) 2014/30/EU (EMC - Electro Magnetic Compatibility) 2011/65/EU, 2015/863/EU (Electric-electronic equipment hazardous substances)
Standards	Electromagnetic compatibility (EMC) - emissions and immunity: EN IEC 62052-11:2021/A11:2022 (Emissions according to CISPR 32:2015, class B) Electrical safety: EN IEC 61010-1, EN IEC 62052-31:2016, EN IEC 61010-2-030 Metrology: EN IEC 62053-22, EN IEC 62053-23, EN 50470-3:2022 (MID), EN IEC 61557-12 (active power and active energy, MID models only) Durability: EN IEC 62059-32-1:2012
Approvals	  

Electrical specifications

Electrical system	
Managed electrical system	Two-phase (3-wire) Three-phase with neutral (4-wire) Three-phase without neutral (3-wire) Wild leg system (three-phase, four-wire delta)
MID managed electrical system	Three-phase with neutral (4-wire) Three-phase without neutral (3-wire) (ARON)

Voltage inputs - MID	
Voltage connection	Direct
Rated voltage L-N	230 V
Rated voltage L-L	400 V
Voltage tolerance	From 0.8 to 1.15 U_n
Overload	Continuous: 1.5 U_n max.
Input impedance	Refer to "Power supply"
Frequency	50 Hz
Voltage inputs - Non MID models	
Voltage connection	Direct
Rated voltage L-N (from U_n minimum to U_n maximum)	120 to 240 V
Rated voltage L-L (from U_n minimum to U_n maximum)	208 to 415 V
Voltage tolerance	From 0.8 to 1.15 U_n
Overload	Continuous: 1.5 U_n max.
Input impedance	Refer to "Power supply"
Frequency	From 45 to 65 Hz

Note: for MID versions the voltage range is limited to 3x120 (208)...3x230 (400) V, frequency to 50Hz.

Note: EM530 can also be installed in a wild leg system (three phases, four delta wires), where one of the phase-neutral voltages is higher than the other two.

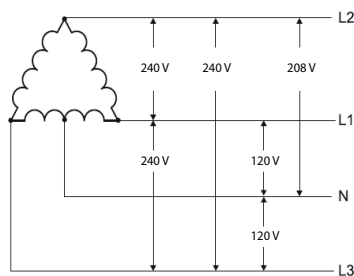

Fig. 4 Two-phase system with neutral (3-wire)

Current inputs	AV5	MV5
Current connection	Via CT	Via 333 mV current sensor
CT transformation ratio	2000 max.	-
Primary current	10 kA max.	10 kA max.
Rated current (I_n) input	5 A	333 mV
Minimum current (I_{min})	0.05 A	0.02 I_n (0.07 V)
Maximum current (I_{max})	6 A	1.2 I_n (0.4 V)
Start-up current (I_{st})	10 mA	0.2% I_n
Threshold current (I_{tr})	0.05 I_n	0.05 I_n
Overload	For 500 ms: 20 I_{max} (120 A)	For 500 ms: 20 I_{max}
Input impedance	< 0.3 VA	100 k Ω
Crest factor	3	1.414 @ I_{max}
Measurement type	by means of internal shunts	with external current sensors

Power supply

Type	Self power supply
Consumption	< 1.3 W / 2.6 VA
Frequency	50/60 Hz

Measurements

Method	TRMS measurements of distorted waveforms
--------	--

Available measurements

Active energy	Unit	System	Phase
Imported (+) Total	kWh+	•	•
Imported (+) partial	kWh+	•	-
Exported (-) Total	kWh-	•	-
Exported (-) partial	kWh-	•	-
Imported (+) Total by tariff (t1, t2)	kWh+	•	-

Reactive energy	Unit	System	Phase
Imported (+) Total	kvarh+	•	-
Imported (+) partial	kvarh+	•	-
Exported (-) Total	kvarh-	•	-
Exported (-) partial	kvarh-	•	-

Apparent energy	Unit	System	Phase
Total	kVAh	•	-
Partial	kVAh	•	-

Run hour meter	Unit	System	Phase
Total (kWh+)	hh:mm	•	-
Partial (kWh+)	hh:mm	•	-
Total (kWh-)	hh:mm -	•	-
Partial (kWh-)	hh:mm -	•	-
Total ON time	hh:mm	•	-

Electrical variable	Unit	System	Phase
Voltage L-N	V	•	•
Voltage L-L	V	•	•
Current	A	•	•
DMD	A	-	•
DMD MAX.	A	-	•
Neutral current	A	•	-
Active power	W	•	•
DMD	W	•	-
DMD MAX.	W	•	-
Apparent power	VA	•	•
DMD	VA	•	-
DMD MAX.	VA	•	-
Reactive power	Var	•	•
Power factor	PF	•	•
Frequency	Hz	•	-
THD Current*	THD A %	-	•
THD Voltage L-N*	THD L-N %	-	•
THD Voltage L-L*	THD L-L %	-	•

* Up to 15th harmonic

Note: the available variables depend on the type of system set.

PFA, PFB and PFC models: Total imported active energy (kWh TOT) is the only MID certified meter. Apparent energy, reactive energy and exported active energy are not MID certified. Partial meters are not MID certified. PFD and PFE models: Total imported active energy (kWh+ TOT) and Total exported active energy (kWh- TOT) are the only MID certified meters. Apparent energy, reactive energy are not MID certified. Partial meters are not MID certified.

All the variables calculated by the meter are referred to the primary current of the current transformer.

Energy metering

Energy metering depends on the measurement type you chose (selectable in non-MID models, according to the model in MID-certified models).

A measurement (Easy connection)

Models: MID PFA

Irrespective of the current direction, the power always has a plus sign and contributes to increase the positive energy meter. The negative energy meter is not available.

B measurement (Bidirectional)

Models: MID PFB and PFD

For each measuring time interval, the individual phase energies with a plus sign are summed to increase the positive energy meter (kWh+), while the others increase the negative one (kWh-).

Example:

P L1= +2 kW, P L2= +2 kW, P L3= -3 kW

Integration time = 1 hour

kWh+ = (2+2) x 1h = 4 kWh

kWh- = 3 x 1h = 3 kWh

C measurement (Net Bidirectional)

Models: MID PFC and PFE

For every measuring interval time, the energies of the single phases are summed; according to the sign of the result, the positive (kWh+) or negative totalizer (kWh-) is increased.

Example:

P L1= +2 kW, P L2= +2 kW, P L3= -3 kW

Integration time = 1 hour

kWh+ = (+2+2-3) x 1h = (+1) x 1h = 1 kWh

kWh- = 0 kWh

Measurement accuracy

Current AV5	
From 0.05 I_n to I_{max}	$\pm 0.3\%$ rdg
From 0.01 I_n to 0.05 I_n	$\pm 0.6\%$ rdg

Current MV5	
From I_{min} to 0.05 I_n (PF=1)	$\pm 1\%$ rdg
From 0.05 I_n to I_{max} (PF=1)	$\pm 0.5\%$ rdg
From 0.05 I_n to 0.1 I_n (PF=0.5 L - 0.8 C)	$\pm 1\%$ rdg
From 0.1 I_n to I_{max} (PF=0.5 L - 0.8 C)	$\pm 0.6\%$ rdg

Phase-phase voltage	
From U_n minimum -20% to U_n maximum +15%	$\pm 0.2\%$ rdg

Phase-neutral voltage	
From U_n minimum -20% to U_n maximum +15%	$\pm 0.2\%$ rdg

Active and apparent power	AV5	MV5
From 0.05 I_n to I_{max} (PF=1)	$\pm 0.5\%$ rdg	
From 0.01 I_n to 0.05 I_n (PF=1)	$\pm 1\%$ rdg	
From 0.1 I_n to I_{max} (PF=0.5 L - 0.8 C)	$\pm 0.6\%$ rdg	
From 0.02 I_n to 0.1 I_n (PF=0.5 L - 0.8 C)	$\pm 1\%$ rdg	
Active energy	Class 0.5 S EN IEC 62053-22, class B EN 50470-3 (MID)	Equivalent to class 0.5 EN IEC 62053-21

Reactive power	AV5	MV5
From 0.1 I _n to I _{max} (sinφ=0.5 L - 0.5 C) From 0.05 I _n to I _{max} (sinφ=1)	± 2% rdg	
From 0.05 I _n to 0.1 I _n (sinφ=0.5 L - 0.5 C) From 0.02 I _n to 0.05 I _n (PF=1)	± 2.5% rdg	
Reactive energy	Class 2 (EN IEC 62053-23)	Equivalent to class 2 (EN IEC 62053-23)

Frequency	
From 45 to 65 Hz	± 0.1% rdg

Measurement accuracy according to EN IEC 61557-12 (MID models)	
Active power	Performance class 1
Active energy	Performance class 2

Measurement resolution

Variable	Display resolution	Resolution by serial communication
Energy	0.001 kWh/kvarh/kVAh	
Single phase energy	0.01 kWh	0.001 kWh
Power	0.01 kW/kvar/kVA	0.1 W/var/VA
Current*	0.01 A	0.001 A
Voltage	0.1 V	
Frequency	0.01 Hz	0.001 Hz
THD	0.01 %	
Power factor	0.01	0.001

(*)Note: value referred to CT ratio =1.

Display

Type	Segments
Refresh time	500 ms
Description	Backlit LCD
Variable readout	Instantaneous: 5+1 dgt or 5+2 dgt Power factor: 1+2 dgt Energy: 8+3 dgt

 LED
AV5

The LED is Red coloured. Pulse weight: proportional to energy consumption and depending on the CT ratio, 16 Hz maximum frequency.

Weight (kWh per pulse)	CT ratio
0.001	≤ 7
0.01	$7 < CT \leq 70$
0.1	$70 < CT \leq 700$
1	$700 < CT \leq 2000$

MV5

The LED is Red coloured. Pulse weight: proportional to energy consumption and depending on Primary current (I_n), 16Hz maximum frequency.

Weight (kWh per pulse)	Primary current (I_n)
0.001	≤ 35
0.01	$35 < I_n \leq 350$
0.1	$350 < I_n \leq 3500$
1	> 3500

Digital outputs/inputs

Digital inputs

Connection type	Screw terminals
Number of inputs	1
Type	Free contact
Function	Remote status Tariff management Partial meter start/pause Partial meter reset
Features	Open contact voltage: 5 V dc +/- 5% Closed contact voltage: 5 mA max. Input impedance: 11.6 k Ω Open contact resistance: \geq 25 k Ω Closed contact resistance: \leq 840 Ω Maximum voltage applicable with no damages: 30 V ac
Configuration parameters	Input function
Configuration mode	Via keypad or UCS software

Digital output

Connection type	Screw terminals
Maximum number of outputs	1
Type	Opto-mosfet
Function	Pulse output or alarm output
Features	V_{ON} 2.5 V ac/dc, max 100 mA V_{OFF} 42 V ac/dc
Configuration parameters	Output function (pulse/alarm) Pulse weight (from 0.001 to 10 kWh per pulse) Pulse duration (30 or 100 ms) Output normal status (NO or NC)
Configuration mode	Via keypad

Note: type S0, class B in accordance with EN IEC 62053-31.

Communication ports

Modbus RTU

Protocol	Modbus RTU
Devices on the same bus	Max 247 (1/8 unit load)
Communication type	Multidrop, bidirectional
Connection type	2 wires
Configuration parameters	Modbus address (from 1 to 247) Baud rate (9.6/19.2/38.4/57.6/115.2 kbps) Parity (None/Even) Stop bit (1 or 2)
Refresh time	≤ 100 ms
Configuration mode	Via keypad or UCS software

M-Bus

Protocol	M-Bus according to EN13757-3:2013
Devices on the same bus	Max 250 (1 unit load)
Connection type	2 wires
Configuration parameters	Primary address (1 to 250) Baud rate (0.3/2.4/9.6 kbps)
Refresh time	≤ 100 ms
Configuration mode	Via keypad

Connection Diagrams

AV5

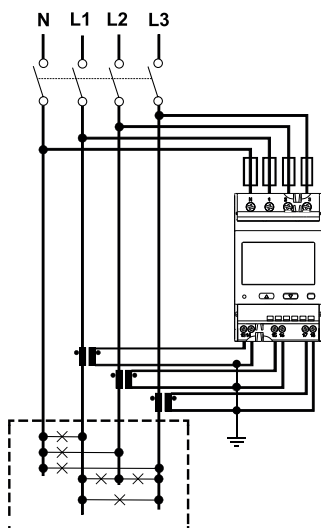

Fig. 5 Three-phase with neutral (4-wire). MID

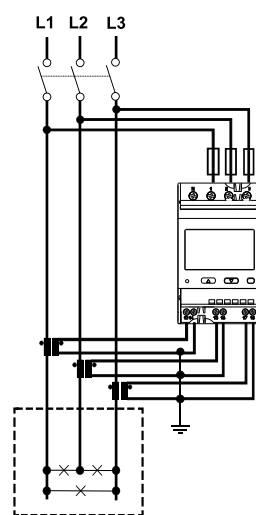

Fig. 6 Three-phase without neutral (3-wire). MID

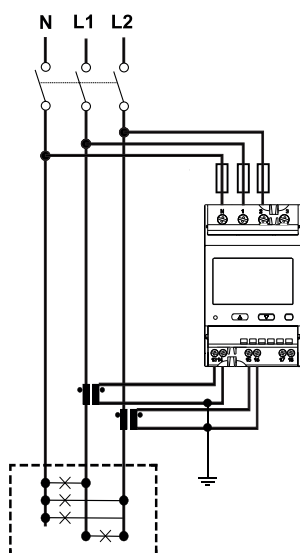

Fig. 7 Two-phase system with neutral (3-wire)

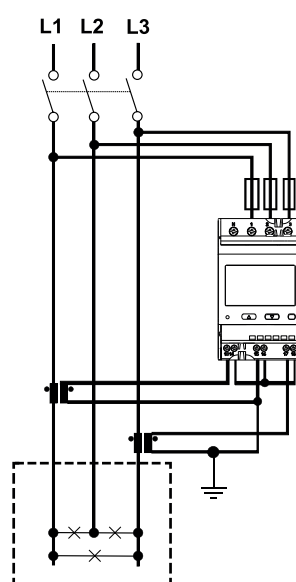

Fig. 8 Three-phase without neutral (3-wire).
MID

MV5

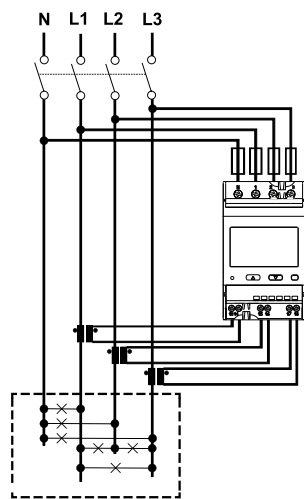

Fig. 9 Three-phase with neutral (4-wire).

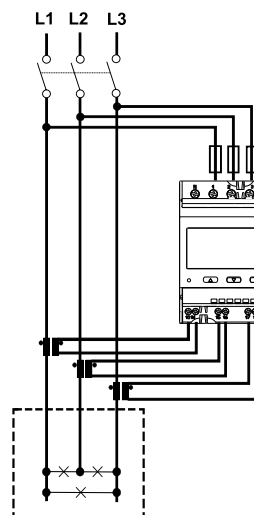

Fig. 10 Three-phase without neutral (3-wire).

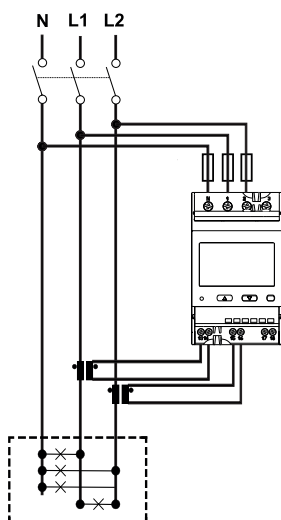

Fig. 11 Two-phase system with neutral (3-wire)

Digital outputs/inputs

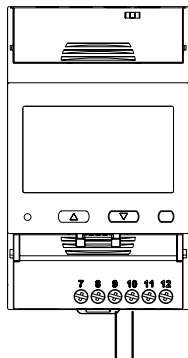

Fig. 12 Output

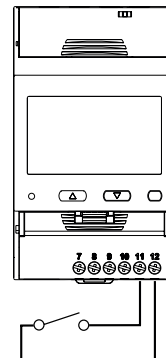

Fig. 13 Input

Communication

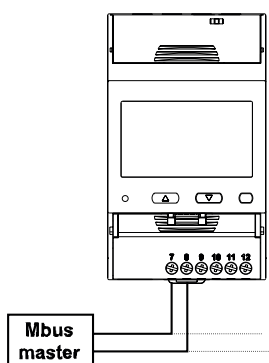

Fig. 14 M-Bus

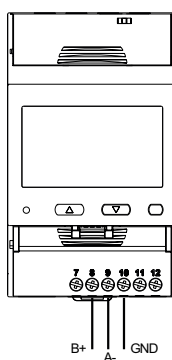

Fig. 15 RS485 port

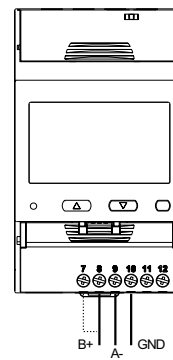

Fig. 16 Last device on RS485

References

Order code

AV5 models with possibility to select different communication systems.

 EM530 DIN AV5 3X

Enter the code option instead of

Code	Options	Description
EM530 DIN AV5 3X	-	-
<input type="checkbox"/>	O1	Digital output
	S1	RS485 Modbus RTU
	M1	M-Bus
<input type="checkbox"/>	X	Non MID models
	PFA	MID models (3P, 3P.n)
	PFB	MID models (3P, 3P.n)
	PFC	MID models (3P, 3P.n)
	PFD	MID models (3P, 3P.n)
	PFE	MID models (3P, 3P.n)

AV5 models with operating temperature up to +70°C.

EM530 DIN AV5 3X S1 70

Enter the code option instead of

Code	Options	Description
EM530 DIN AV5 3X	-	-
S1	-	RS485 Modbus RTU
<input type="checkbox"/>	PFA	MID models (3P, 3P.n)
	PFB	MID models (3P, 3P.n)
	PFC	MID models (3P, 3P.n)
	PFD	MID models (3P, 3P.n)
	PFE	MID models (3P, 3P.n)
70	-	Max operating temperature

MV5 model.

EM530 DIN MV5 3X S1 X

Code	Options	Description
EM530 DIN	-	-
MV5	-	333 mV CT connection
3X	-	-
S1	-	RS485 Modbus RTU
X	-	Non MID models

- PFA: Easy connection, the total energy totalizer (kWh+) is certified according to MID;
- PFB: only the total positive totalizer (kWh+) is certified according to MID. The negative energy totalizer is available but not certified according to MID.

Note: for each measuring time interval, the individual phase energies with a plus sign are summed up to increase the positive energy meter (kWh+), while the others increase the negative one (kWh-).

- PFC: only the positive totalizer (kWh+) is MID-certified. The negative energy totalizer is available but is not MID-certified.

Note: for each measuring time interval, the energies of the individual phases are summed up; according to the sign of the result, the system increases the positive totalizer (kWh+) or the negative one (kWh-).

- PFD: Bidirectional, total imported active energy (kWh+ TOT) and Total exported active energy (kWh- TOT) are MID certified meters; manufactured in Italy.

Note: for each measuring time interval, the individual phase energies with a plus sign are summed up to increase the positive energy meter (kWh+), while the others increase the negative one (kWh-).

- PFE: Bidirectional, total imported active energy (kWh+ TOT) and Total exported active energy (kWh- TOT) are MID certified meters; manufactured in Italy.

Note: for each measuring time interval, the energies of the individual phases are summed up; according to the sign of the result, the system increases the positive totalizer (kWh+) or the negative one (kWh-).

CARLO GAVAZZI compatible components

Purpose	Component name/code key	Notes
Configure analyzer via desktop application	UCS software	Available for free download at: www.gavazziautomation.com
Aggregate, store and transmit data to other systems	UWP	Available for free download at: www.gavazziautomation.com
CT series	CTA, CTD, CTV	Available for free download at: www.gavazziautomation.com

